

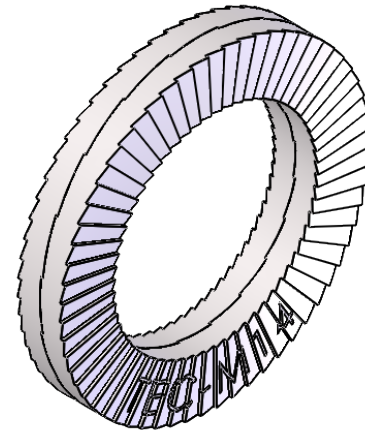

REVISIONS			
REV.	DESCRIPTION	DATE	ECN
A	INITIAL RELEASE	2/27/17	2555
B	HEAT TREAT WAS 480 - 540 HV, MAIN DIMENSION NOW IN MM	3/28/17	2615
C	MATERIAL UPDATE	7/12/2018	3056

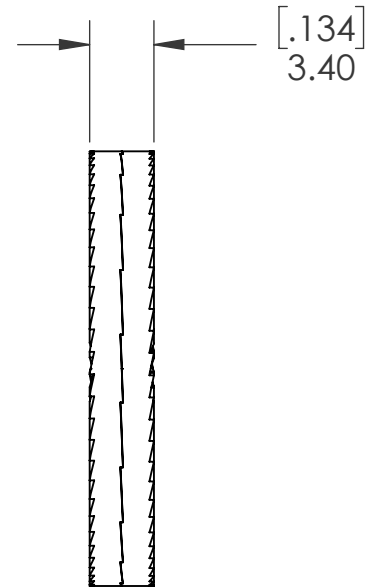
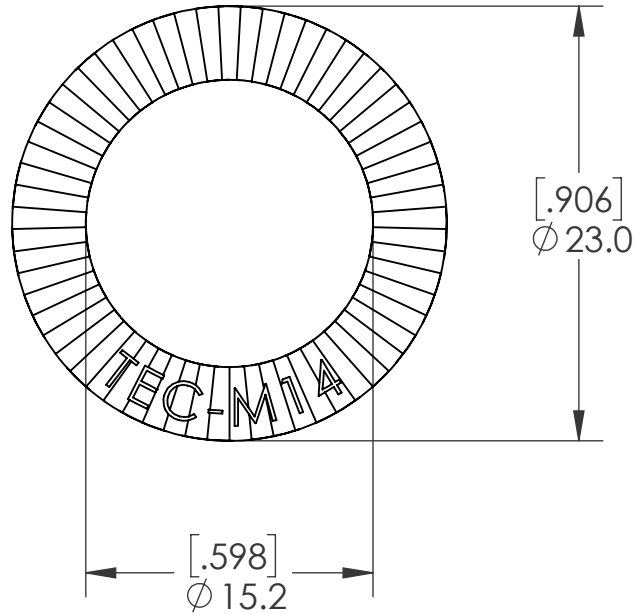

PROPRIETARY AND CONFIDENTIAL
 THIS DRAWING, AND THE INFORMATION CONTAINED HEREIN, ARE THE PROPERTY OF SHEREX AND ARE NOT TO BE USED IN ANY MANNER DETRIMENT TO THE INTEREST OF THE COMPANY.
 SHEREX FASTENING SOLUTIONS RESERVES THE RIGHT TO REVISE PART/DRAWING WITHOUT NOTICE.

DRAWING NO.:
TEC-M14

UNLESS OTHERWISE SPECIFIED:		NAME	DATE	
DIMENSIONS ARE IN MM (INCHES) TOLERANCES: ANGULAR: MACH ± 1 BEND ± 1 I.D. TOLERANCE: ± 0.2 [±.008] O.D. TOLERANCE: ± 0.2 [±.008] THICKNESS TOLERANCE: ± 0.25 [±.01]		DRAWN	MTB	
INTERPRET GEOMETRIC TOLERANCING PER: ASME Y14.5M-1994		CHECKED		
MATERIAL		ENG APPR.	JVK	2/27/17
SCM435 OR 4130 STEEL, HT: THROUGH HARDEN 465 HV MIN		MFG APPR.		
FINISH		Q.A.		
DELTA PROTEKT BASE COAT (KL100) & TOP COAT (VH302GZ)		COMMENTS:		DESCRIPTION: TEC WASHER GLUED PAIR 14MM, 9/16"
DO NOT SCALE DRAWING		E-mail: info@disc-lock.com www.disc-lock.com Phone: 866-474-3739 Fax: 716-875-0358		
		SIZE	PART NO.:	REV
		A	TEC-M14	C
		SCALE: 5:2	WEIGHT:	SHEET 1 OF 1